



SUSTAINABLE COLD SOLUTIONS

CO₂ TRANSCRITICAL RACKS

LEAN BOOSTER

We know the art of achieving
a perfect temperature

BEIJER REF

The lean line offers a range of CO2 units configured as MT only or Booster MT/LT, with the following features:

- Convenient one-side access to components, allowing for wall-mounted installation.
- Available in indoor or «plug'n cool» versions with an integrated gas cooler.



STD EQUIPMENT

- Inverter on MT leading compressor
- Maintenance free high efficiency oil separator
- Oil reservoir with minimum level switch
- Replaceable oil filter strainer
- Electronic oil level regulator for each compressor
- High pressure and Medium pressure valve Danfoss CCMTS
- Vertical liquid receiver with min, operation, high level sign glass and low level switch
- Liquid Injection
- Danfoss controller
- Common discharge manifold for PRV
- Full factory tested and programmed
- Design pressure: 120 / 60 / 52 / 30 bar

OPTIONS

- 2 x Heat recovery (TW & HR)
- Gas cooler bypass
- Ejector HP/LE and LP
- IT-Parallel compressor with Varistep or Inverter
- Varistep on MT compressor
- Inverter on LT
- Inverter on IT
- LSPM Motors
- AC load (flooded evaporator)
- Larger liquid receiver volumes available
- Liquid level control (4-20mA)
- LT suction accumulator
- Suction filter strainer MT-LT installed
- LTGC with 3 way bypass valve
- Outdoor enclosure (reach in)
- Low noise outdoor enclosure (reach in)
- PNC outdoor version
- Back up HP/MP valves
- Back up controller
- Energy meter
- Electrical cabinet remote (demontable with extra cable)
- 130 bar HP / 80 bar MP /60 bar suction MT and LT

PRELIMINARY DATA

	MWL MTDX	MWL MTDX + BT
Number of Compressors MT(IT) / LT	4 (2)	4 (1)/3 (2 if Ejector LE installed)
MT Max. Cooling Capacity MT (kW)	170	50
LT Max. Cooling Capacity LT (kW)		50
A/C Max. Cooling Load (kW)	30	30
Liquid receiver volume [litres]	70 - 124 - 170 - 170AC 240AC - 300	
Suction line connection MT [inch]	1"3/8 - 1"5/8	1"3/8 - 1"5/8
Suction line connection LT [inch]	-	7/8" - 1"1/8
Liquid line connection [inch]	7/8" - 1"3/8	7/8" - 1"3/8
Frequency Inverter range MT [Hz]	25-70	25-70
Frequency Inverter range LT (option) [Hz]	30-70	30-70
Electrical supply compressors / mainline [V/ph/Hz]	400/3+N/50	400/3+N/50
Max dimensions LxWxH (mm)		
2+2	3210x900x1950	3210x900x1950
3+3	3820x900x2050	3820x900x2050
4+3	4310x900x2050	4310x900x2050

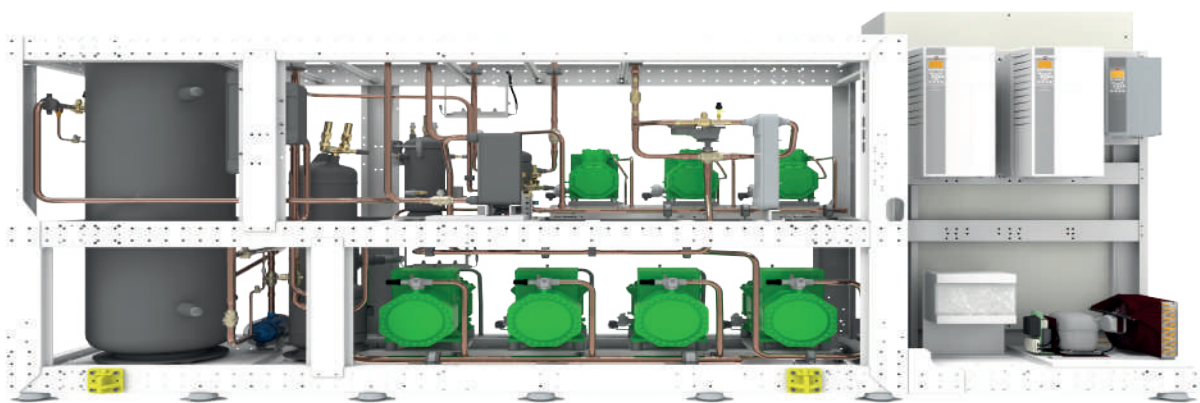

DIMENSIONAL DATA

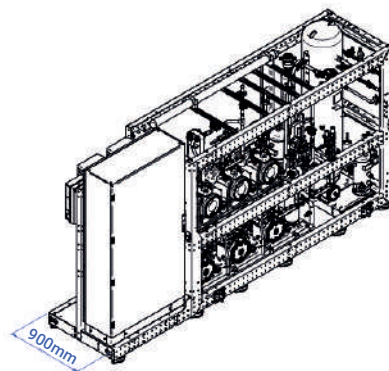
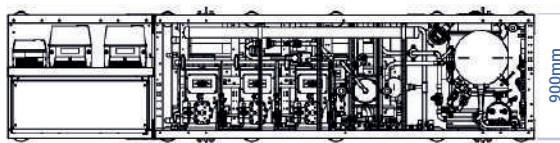
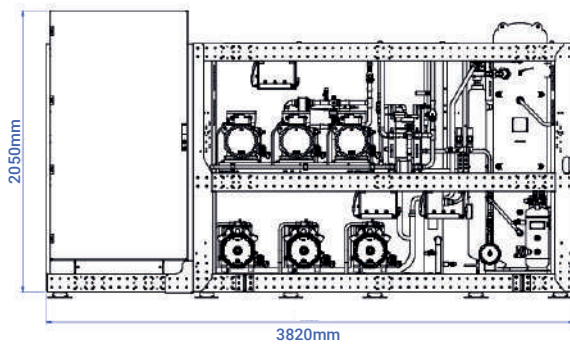
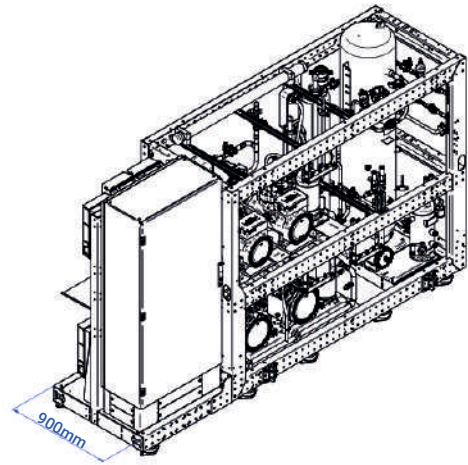
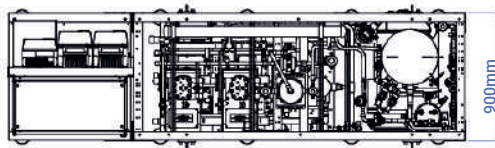
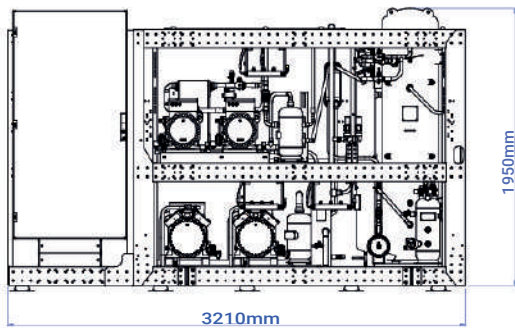

DIMENSIONAL

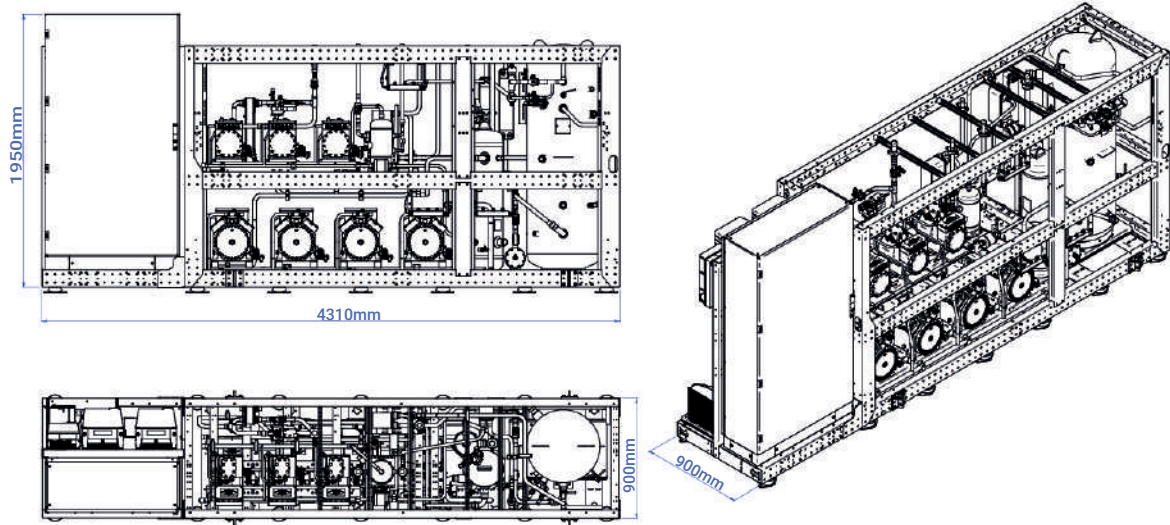

PRODUCTS / APPLICATIONS RANGE

Commercial Refrigeration

- Small Shops
- Restaurants
- Catering
- Petrol Stations

- Convenience stores
- Express supermarkets

- Supermarkets
- Coldrooms for food storing

Industrial Refrigeration

- Food processes
- Hypermarkets
- Logistic Centers

BOOSTER - MWT

LEAN BOOSTER - MWL

SMART BOOSTER - MWS

CONTACT INFO

 +39 049 970 5000

 info@scmfrigo.com

 www.scmfrigo.com

 [SCM Frigo S.p.A.](#)

