



SUSTAINABLE COLD SOLUTIONS

TRANSCRITICAL CO₂ CONDENSING UNITS



Available with
**VARISTEP
CRII**



We know the art of achieving
a perfect temperature



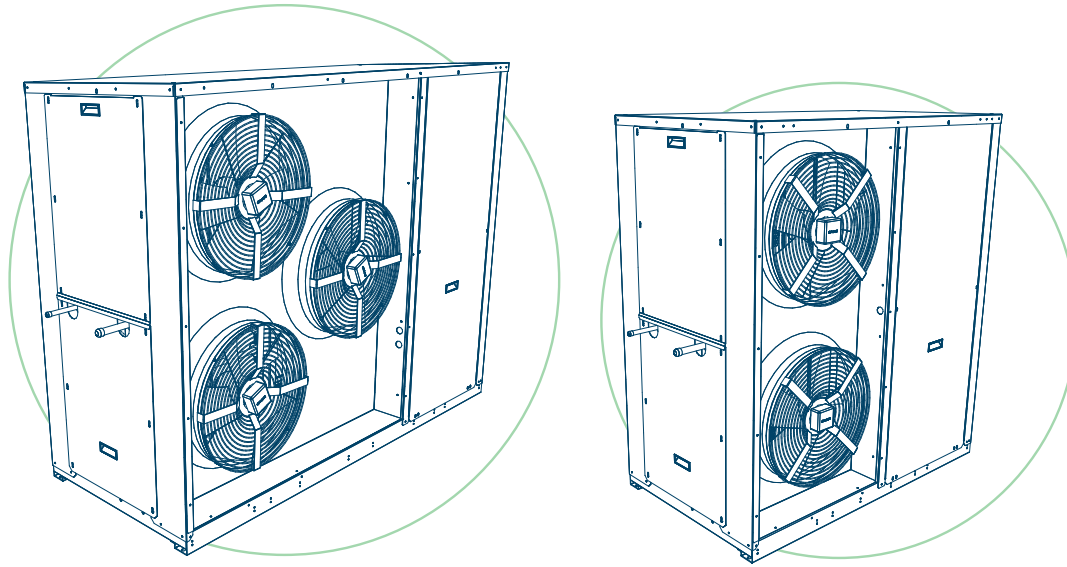

BEIJER REF



Product Description

Condensing unit for transcritical CO₂ applications equipped with BITZER/DORIN semi-hermetic piston compressors with frequency inverter or BITZER CR11, integrated air cooled gas cooler and EC fans. It is a high-efficiency solution designed for a small footprint and low noise.

Main Advantages

 <p>COMPACT DESIGN</p>	 <p>EASY START-UP</p>	 <p>EASY TO INSTALL AND MAINTAIN</p>	 <p>TESTED AND FACTORY PROGRAMMED</p>	 <p>EFFICIENCY UP IN ALL CLIMATE THANKS TO EJECTOR</p>
---	--	---	--	--

Cooling Capacity

Transcritical condensing units DX

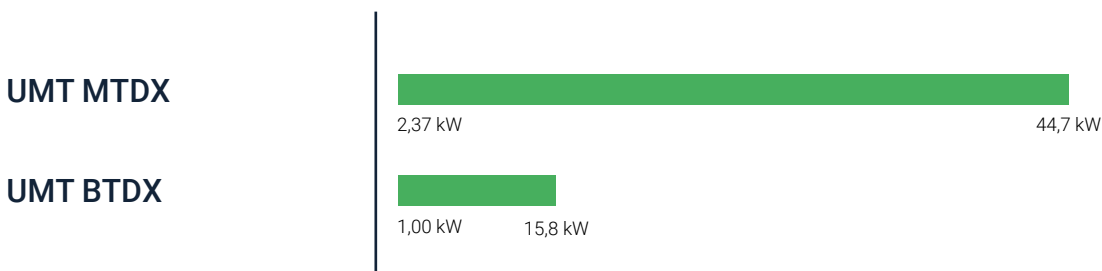

Standard Accessories

- SEMIHERMETIC RECIPROCATING COMPRESSOR
- CAREL CONTROLLER
- INVERTER MODULATION FOR CAPACITY CONTROL 60% - 140% OR BITZER CRII FOR CAPACITY MODULATION 10% - 100%
- INTEGRATED GAS COOLER WITH EC FANS
- DESIGN PRESSURE: 130 BAR (HIGH PRESSURE SIDE) | 80 BAR (LIQUID LINE) | 80 BAR (SUCTION LINE)
- POWER SUPPLY 400V/3+N/50HZ
- LIQUID RECEIVER 15 LITERS (PED III)
- K65 CONNECTIONS

Accessories on Request

- LIQUID RECEIVER 37 LITERS (PED III)
- ADIABATIC KIT WATER SPRAY, INCLUDING CONTROLLER
- RDM/DANFOSS/WURM CONTROLLER
- EPOXY OR ELECTROFIN GAS COOLER CORROSION COIL PROTECTION

Check the Unit CO₂ Charge / Receiver Size



Cooling Capacity:
MT from 4,6 kW up to 34 kW
BT from 1,1 kW up to 12,5 kW

Design is compact and units are easy to install and maintain.
Units are equipped with gas cooler and electrical panel, tested and factory programmed for an easy start-up.

[DOWNLOAD BROCHURE](#)

[CO₂ CHARGE CALCULATION EURO PLUS V1.1](#)

1_ Enter our website www.scmfrigo.com

2_ Click on the 'Products' section at the top

3_ Click within the product group 'CO₂ Condensing Units'.

4_ Finally, click here! 

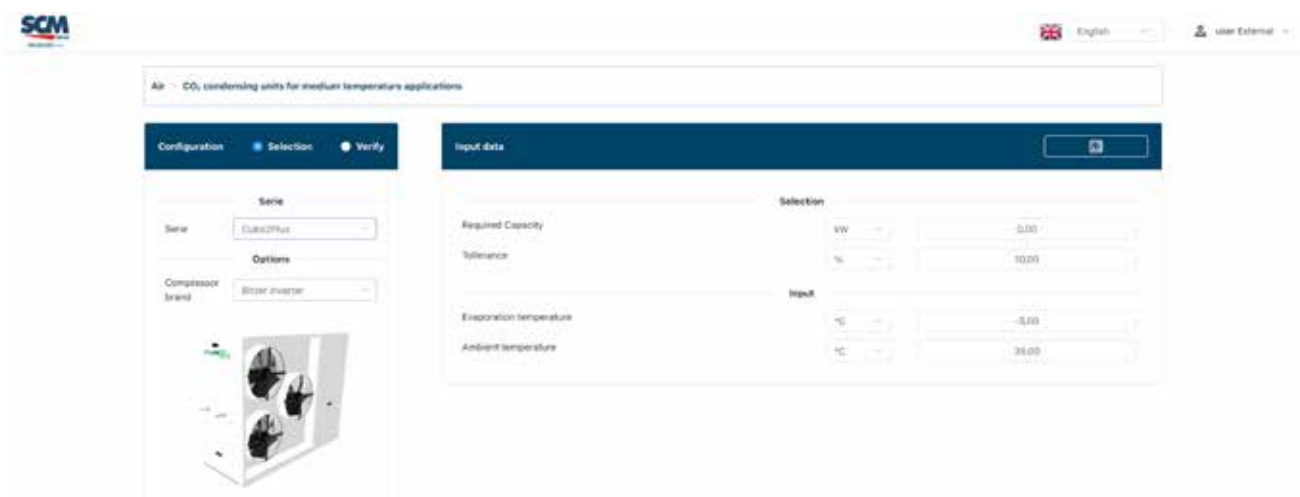

The screenshot shows the web interface for the CO₂ calculation tool. It includes a navigation bar with the SCM logo, language selection (English), and user information (user External). The main content area is titled 'Air - CO₂ condensing units for medium temperature applications'. It features a 'Configuration' section with 'Selection' and 'Verify' tabs. Under 'Selection', there are dropdown menus for 'Serie' (Cubo2Plus) and 'Compressor brand' (Bitzer inverter). Below this is a 'Verify' section with a product image. To the right is the 'Input data' section, which includes 'Required Capacity' (kW) and 'Tolerance' (%), and an 'Input' section with 'Evaporation temperature' (°C) and 'Ambient temperature' (°C). The input fields are currently set to 0.00, 10.00, -5.00, and 36.00 respectively.

<https://cubo2calculation.scmfrigo.com/#/home>

AT THE FOLLOWING LINK YOU CAN CHECK THE UNIT CHARGE/RECEIVER SIZE.
Ask our sales department for the password

T amb [°C]		Evaporation Temperature[°C]																			
		-15				-10				-5				0				5			
		Cooling Capacity [kW]		Pe	COP	Cooling Capacity [kW]		Pe	COP	Cooling Capacity [kW]		Pe	COP	Cooling Capacity [kW]		Pe	COP	Cooling Capacity [kW]		Pe	COP
min	max	kW		min	max	kW		min	max	kW		min	max	kW		min	max	kW			
UMT 036 MTDX Bitzer 2MTE-5K	40	2,85	5,70	5,23	1,09	3,48	6,95	5,93	1,17	4,19	8,38	6,13	1,37	4,98	9,97	6,29	1,58	5,91	11,82	6,39	1,85
	38	2,98	5,97	5,09	1,17	3,65	7,29	5,77	1,26	4,40	8,81	5,96	1,48	5,24	10,48	6,09	1,72	6,20	12,40	6,15	2,02
	32	3,46	6,92	4,64	1,49	4,24	8,48	5,26	1,61	5,11	10,23	5,37	1,91	6,03	12,05	5,40	2,23	6,94	13,87	5,36	2,59
	25	4,09	8,18	4,58	1,79	5,04	10,08	5,19	1,94	6,15	12,31	5,28	2,33	7,45	14,90	5,30	2,81	8,87	17,75	5,24	3,39
	15	4,97	9,94	3,57	2,78	6,05	12,11	4,03	3,00	7,19	14,38	4,02	3,58	8,45	16,90	3,96	4,27	9,80	19,60	3,81	5,14
	5	5,93	11,86	2,97	3,99	7,21	14,42	3,34	4,32	8,55	17,11	3,24	5,28	10,09	20,17	3,10	6,51	11,69	23,37	2,86	8,17
	N. of fans 2x500																				
	Weight 460 kg																				
	Sound pressure 43 dB(A)*																				
	Minimum Energy Performance Standards 2,75 (according Ecodesign Directive EN 2009/125/EC)																				
Annual Energy Consumption 18927 kWh/year																					
MRA/Pmax 15,9 A / 7,5 kW																					
UMT 075 MTDX Bitzer 2KTE-7K	40	4,11	8,22	7,88	1,04	5,05	10,09	8,24	1,23	6,13	12,26	8,54	1,44	7,35	14,69	8,77	1,68	8,65	17,30	8,91	1,94
	38	4,31	8,62	7,68	1,12	5,29	10,58	8,01	1,32	6,42	12,83	8,28	1,55	7,67	15,33	8,48	1,81	8,99	17,97	8,57	2,10
	32	5,00	10,00	7,04	1,42	6,09	12,19	7,27	1,68	7,25	14,49	7,42	1,95	8,36	16,73	7,49	2,23	9,37	18,73	7,43	2,52
	25	5,96	11,92	6,94	1,72	7,33	14,65	7,16	2,05	8,89	17,78	7,29	2,44	10,64	21,28	7,33	2,90	12,50	25,00	7,25	3,45
	15	7,11	14,21	5,58	2,55	8,48	16,96	5,67	2,99	9,99	19,98	5,70	3,51	11,64	23,28	5,64	4,12	13,43	26,86	5,50	4,88
	5	8,51	17,02	4,74	3,59	10,09	20,18	4,73	4,27	11,83	23,66	4,64	5,10	13,73	27,47	4,48	6,13	15,80	31,60	4,24	7,46
	N. of fans 2x500																				
	Weight 470 kg																				
	Sound pressure 44 dB(A)*																				
	Minimum Energy Performance Standards 2,78 (according Ecodesign Directive EN 2009/125/EC)																				
Annual Energy Consumption 26966 kWh/year																					
MRA/Pmax 20,5 A / 10,4 kW																					
UMT 120 MTDX Bitzer 4MTE-10K	40	5,39	10,79	10,33	1,04	6,70	13,40	11,02	1,22	8,13	16,26	11,50	1,41	9,64	19,29	11,78	1,64	11,18	22,37	11,87	1,88
	38	5,70	11,39	10,20	1,12	7,04	14,08	10,78	1,31	8,48	16,95	11,16	1,52	9,97	19,94	11,34	1,76	11,43	22,87	11,34	2,02
	32	6,61	13,22	9,53	1,39	7,88	15,76	9,81	1,61	9,05	18,09	9,92	1,82	10,10	20,19	9,84	2,05	11,06	22,13	9,63	2,30
	25	8,02	16,04	9,41	1,70	9,86	19,71	9,65	2,04	11,86	23,72	9,72	2,44	13,89	27,79	9,62	2,89	15,72	31,45	9,36	3,36
	15	9,26	18,52	7,65	2,42	11,02	22,04	7,73	2,85	12,95	25,90	7,73	3,35	15,05	30,10	7,64	3,94	17,33	34,65	7,47	4,64
	5	11,07	22,14	6,44	3,44	13,00	26,00	6,28	4,14	15,37	30,74	6,37	4,82	17,82	35,64	6,24	5,71	20,47	40,95	6,05	6,77
	N. of fans 2x500																				
	Weight 570 kg																				
	Sound pressure 44 dB(A)*																				
	Minimum Energy Performance Standards 2,68 (according Ecodesign Directive EN 2009/125/EC)																				
Annual Energy Consumption 36104 kWh/year																					
MRA/Pmax 26,3 A / 13,8 kW																					
UMT 150 MTDX Bitzer 4KTE-12K	40	8,18	16,35	15,20	1,08	10,13	20,27	15,80	1,28	12,24	24,48	16,32	1,50	14,44	28,88	16,72	1,73	16,64	33,29	16,96	1,96
	38	8,61	17,22	14,78	1,17	10,62	21,23	15,33	1,39	12,73	25,47	15,79	1,61	14,89	29,78	16,11	1,85	16,99	33,98	16,26	2,09
	32	9,80	19,59	13,45	1,46	11,66	23,31	13,82	1,69	13,35	26,69	14,06	1,90	14,86	29,72	14,11	2,11	16,25	32,51	13,95	2,33
	25	11,96	23,92	13,25	1,80	14,73	29,47	13,60	2,17	17,70	35,41	13,79	2,57	20,66	41,33	13,80	2,99	23,29	46,58	13,58	3,43
	15	13,83	27,66	10,80	2,56	16,41	32,82	11,01	2,98	19,26	38,51	11,10	3,47	22,38	44,76	11,06	4,05	25,79	51,58	10,85	4,76
	5	16,93	33,87	9,19	3,69	19,80	39,61	9,22	4,30	23,00	45,99	9,13	5,04	26,55	53,09	8,90	5,97	30,44	60,87	8,53	7,14
	N. of fans 3x500																				
	Weight 645 kg																				
	Sound pressure 45 dB(A)*																				
	Minimum Energy Performance Standards 2,74 (according Ecodesign Directive EN 2009/125/EC)																				
Annual Energy Consumption 52347 kWh/year																					
MRA/Pmax 33,4 A / 18,6 kW																					
UMT 190 MTDX Bitzer 4HTE-20K	40	10,63	21,27	18,66	1,14	12,80	25,60	19,60	1,31	15,11	27,67	18,61	1,49	17,40	29,00	17,31	1,67	19,60	32,67	17,53	1,86
	38	11,12	22,25	18,20	1,22	13,26	26,53	19,01	1,40	15,49	28,38	17,96	1,58	17,65	29,41	16,62	1,77	19,68	32,80	16,75	1,96
	32	13,13	26,25	17,29	1,52	13,73	27,46	17,01	1,61	17,29	31,67	16,42	1,93	20,14	33,56	15,33	2,19	23,11	38,51	15,64	2,46
	25	15,54	31,08	16,32	1,90	18,47	36,93	16,70	2,21	21,40	39,19	15,46	2,54	23,92	39,87	14,02	2,84	25,97	43,29	13,85	3,13
	15	17,08	34,16	13,50	2,53	20,02	40,04	13,75	2,91	23,31	42,70	12,75	3,35	26,87	44,78	11,67	3,84	30,70	51,17	11,68	4,38
	5	20,22	40,44	11,58	3,49	23,66	47,33	11,65	4,06	27,51	50,39	10,72	4,70	31,63	52,72	9,76	5,40	36,05	60,08	9,74	6,17
	N. of fans 3x500																				
	Weight 655 kg																				
	Sound pressure 45 dB(A)*																				
	Minimum Energy Performance Standards 2,71 (according Ecodesign Directive EN 2009/125/EC)																				
Annual Energy Consumption 62283 kWh/year																					
MRA/Pmax 42,4 A / 24 kW																					

NOTE: Inverter modulation from 30 to 60 Hz except / cooling capacity min @30Hz - @60Hz except** @50Hz
 (*based on free field area weed semi-spherical sound emission in 10m distance; tolerance ± 2 dB(A))

T amb [°C]		Evaporation Temperature[°C]																					
		-15			-10			-5			0			5									
		Cooling Capacity [kW]		Pe	Cooling Capacity [kW]		Pe	Cooling Capacity [kW]		Pe	Cooling Capacity [kW]		Pe	Cooling Capacity [kW]		Pe							
		min	max	COP	min	max	COP	min	max	COP	min	max	COP	min	max	COP							
UMT 036 MTDX	Dorin CD 360H	40	1,96	3,93	4,39	0,89	2,46	4,92	4,60	1,07	3,03	6,05	4,77	1,27	3,65	7,30	4,90	1,49	4,33	8,65	4,99	1,74	
		38	2,07	4,14	4,32	0,96	2,59	5,17	4,51	1,15	3,18	6,35	4,66	1,36	3,83	7,65	4,77	1,60	4,53	9,05	4,83	1,88	
		32	2,44	4,88	4,08	1,20	3,03	6,06	4,20	1,44	3,69	7,39	4,27	1,73	4,43	8,85	4,30	2,06	5,22	10,44	4,28	2,44	
		25	2,90	5,80	4,04	1,44	3,60	7,20	3,98	1,81	4,39	8,77	4,21	2,08	5,26	10,52	4,23	2,49	6,21	12,41	4,19	2,96	
		15	3,65	7,29	3,59	2,03	4,41	8,81	3,20	2,75	5,40	10,80	3,57	3,03	6,43	12,86	3,47	3,70	7,54	15,08	3,32	4,54	
		5	4,46	8,93	3,00	2,97	5,41	10,83	2,63	4,12	6,48	12,96	2,78	4,67	7,66	15,32	2,58	5,95	8,93	17,87	2,31	7,75	
		N. of fans 2x500																					
		Weight 460 kg																					
		Sound pressure 43 dB(A)*																					
		Minimum Energy Performance Standards 2,56 (according Ecodesign Directive EN 2009/125/EC)																					
Annual Energy Consumption 19150 kWh/year																							
MRA/Pmax 15,9 A / 7,5 kW																							
UMT 075 MTDX	Dorin CD 4 75-4.7 H	40	4,10	8,20	7,71	1,06	5,01	10,02	8,04	1,25	5,99	11,97	8,28	1,45	6,98	13,97	8,45	1,65	7,96	15,92	8,52	1,87	
		38	4,27	8,55	7,53	1,14	5,20	10,40	7,81	1,33	6,18	12,36	8,02	1,54	7,17	14,33	8,15	1,76	8,11	16,22	8,18	1,98	
		32	4,81	9,61	6,91	1,39	5,68	11,36	7,08	1,60	6,51	13,02	7,17	1,82	7,25	14,49	7,16	2,02	7,89	15,77	7,05	2,24	
		25	5,88	11,77	6,82	1,73	7,14	14,28	6,97	2,05	8,49	16,98	7,04	2,41	9,85	19,70	7,01	2,81	11,13	22,25	6,88	3,23	
		15	7,12	14,23	5,86	2,43	8,41	16,83	5,85	2,88	9,57	19,15	5,74	3,34	10,43	20,86	5,53	3,77	11,50	22,99	5,22	4,41	
		5	7,98	15,96	4,71	3,39	9,17	18,33	4,53	4,05	10,86	21,73	4,25	5,11	12,72	25,44	3,86	6,58	14,72	29,43	3,37	8,74	
		N. of fans 2x500																					
		Weight 650 kg																					
		Sound pressure 45 dB(A)*																					
		Minimum Energy Performance Standards 2,67 (according Ecodesign Directive EN 2009/125/EC)																					
Annual Energy Consumption 26174 kWh/year																							
MRA/Pmax 20,5 A / 10,4 kW																							
UMT 120 MTDX	Dorin CD4 90-6.4H	40	5,66	11,32	10,33	1,10	6,93	13,86	10,78	1,29	8,30	16,60	11,13	1,49	9,69	19,38	11,37	1,70	11,03	22,05	11,50	1,92	
		38	5,91	11,82	10,08	1,17	7,21	14,42	10,48	1,38	8,58	17,16	10,78	1,59	9,94	19,88	10,97	1,81	11,21	22,43	11,04	2,03	
		32	6,69	13,37	9,24	1,45	7,90	15,80	9,48	1,67	9,00	18,00	9,61	1,87	9,95	19,90	9,63	2,07	10,78	21,56	9,52	2,27	
		25	8,10	16,21	9,11	1,78	9,86	19,72	9,33	2,11	11,73	23,47	9,43	2,49	13,58	27,16	9,41	2,89	15,20	30,40	9,27	3,28	
		15	9,85	19,71	7,80	2,53	11,71	23,42	7,81	3,00	13,28	26,57	7,70	3,45	14,36	28,72	7,47	3,84	15,75	31,49	7,12	4,42	
		5	11,74	23,49	6,27	3,75	12,55	25,10	6,08	4,13	14,86	29,72	5,79	5,13	17,38	34,75	5,38	6,46	20,08	40,15	4,88	8,24	
		N. of fans 2x500																					
		Weight 570 kg																					
		Sound pressure 45 dB(A)*																					
		Minimum Energy Performance Standards 2,75 (according Ecodesign Directive EN 2009/125/EC)																					
Annual Energy Consumption 35268 kWh/year																							
MRA/Pmax 26,3 A / 13,8 kW																							
UMT 150 MTDX	CD4 120-9.2H	40	8,09	16,18	14,79	1,09	9,95	19,90	15,46	1,29	12,01	24,02	16,00	1,50	14,21	28,41	16,40	1,73	16,45	32,91	16,66	1,98	
		38	8,46	16,91	14,43	1,17	10,38	20,76	15,03	1,38	12,50	24,99	15,50	1,61	14,73	29,46	15,83	1,86	16,98	33,95	16,00	2,12	
		32	9,72	19,45	13,24	1,47	13,61	27,22	16,92	1,61	15,10	30,21	17,08	1,77	14,13	28,26	13,98	2,02	17,77	35,54	13,94	2,55	
		25	11,56	23,13	13,06	1,77	14,10	28,21	13,40	2,10	16,92	33,85	13,60	2,49	19,95	39,91	13,65	2,92	23,05	46,11	13,56	3,40	
		15	14,10	28,20	11,24	2,51	17,03	34,05	11,30	3,01	20,22	40,45	11,23	3,60	23,48	46,96	11,05	4,25	26,44	52,87	10,75	4,92	
		5	16,75	33,51	9,15	3,66	19,94	39,88	9,03	4,42	23,05	46,10	8,81	5,23	25,73	51,47	8,51	6,05	28,31	56,61	8,13	6,97	
		N. of fans 3x500																					
		Weight 560 kg																					
		Sound pressure 44 dB(A)*																					
		Minimum Energy Performance Standards 2,83 (according Ecodesign Directive EN 2009/125/EC)																					
Annual Energy Consumption 51217 kWh/year																							
MRA/Pmax 33,4 A / 18,6 kW																							
UMT 190 MTDX	Dorin CD 2000H	40	10,64	21,29	18,81	1,13	12,86	25,72	19,50	1,32	15,10	30,21	20,01	1,51	17,25	28,75	16,93	1,70	18,88	31,47	17,16	1,83	
		38	11,05	22,10	18,27	1,21	13,25	26,50	18,88	1,40	15,42	30,84	19,31	1,60	17,44	29,07	16,24	1,79	18,86	31,44	16,38	1,92	
		32	12,92	25,84	17,29	1,49	15,41	30,81	17,76	1,74	17,76	35,52	18,03	1,97	19,83	33,05	15,08	2,19	21,58	35,97	14,95	2,41	
		25	15,23	30,45	16,31	1,87	18,22	36,45	16,62	2,19	21,08	42,16	16,74	2,52	22,78	37,97	13,64	2,78	24,42	40,71	13,48	3,02	
		15	17,95	35,91	13,84	2,59	20,14	40,29	13,81	2,92	21,79	43,58	13,59	3,21	26,32	43,86	11,49	3,82	36,12	60,20	11,52	5,23	
		5	19,84	39,67	11,05	3,59	23,73	47,45	10,71	4,43	28,03	56,07	10,20	5,50	30,99	51,64	9,63	5,36	35,21	58,68	9,68	6,07	
		N. of fans 3x500																					
		Weight 655 kg																					
		Sound pressure 45 dB(A)*																					
		Minimum Energy Performance Standards 2,85 (according Ecodesign Directive EN 2009/125/EC)																					
Annual Energy Consumption 66470 kWh/year																							
MRA/Pmax 42,4 A / 24 kW																							

NOTE: Inverter modulation from 30 to 60 Hz except / cooling capacity min @30Hz - @60Hz except** @50Hz
 (*based on free field area weed semi-spherical sound emission in 10m distance; tolerance ± 2 dB(A))

T _{amb} [°C]		Evaporation Temperature[°C]																			
		-15				-10				-5				0				5			
		Cooling Capacity [kW]		Pe	COP	Cooling Capacity [kW]		Pe	COP	Cooling Capacity [kW]		Pe	COP	Cooling Capacity [kW]		Pe	COP	Cooling Capacity [kW]		Pe	COP
min	max			min	max			min	max			min	max			min	max				
UMT 075 VS MTDX Bitzer 4PTE-7K	40	0,69	6,85	6,26	1,10	0,84	8,42	6,55	1,29	1,02	10,25	6,81	1,51	1,23	12,35	7,00	1,76	1,47	14,71	7,13	2,06
	38	0,72	7,18	6,09	1,18	0,88	8,84	6,36	1,39	1,08	10,75	6,59	1,63	1,29	12,94	6,76	1,92	1,54	15,39	6,85	2,25
	32	0,84	8,36	5,55	1,51	1,03	10,28	5,74	1,79	1,24	12,45	5,88	2,12	1,48	14,82	5,94	2,50	1,72	17,19	5,91	2,91
	25	0,99	9,93	5,47	1,82	1,22	12,21	5,65	2,16	1,48	14,84	5,77	2,57	1,78	17,84	5,81	3,07	2,12	21,22	5,75	3,69
	15	1,22	12,23	4,23	2,89	1,46	14,64	4,28	3,42	1,73	17,30	4,28	4,05	2,02	20,24	4,21	4,81	2,34	23,45	4,07	5,76
	5	1,46	14,64	3,51	4,18	1,74	17,41	3,47	5,02	2,05	20,48	3,37	6,07	2,39	23,88	3,21	7,44	2,76	27,59	2,98	9,26
	N. of fans 2x500																				
	Weight 470 kg																				
	Sound pressure 44 dB(A)*																				
	Minimum Energy Performance Standards 3,14 (according Ecodesign Directive EN 2009/125/EC)																				
Annual Energy Consumption 20096 kWh/year																					
MRA/Pmax 20,5 A / 10,4 kW																					
UMT 120 VS MTDX Bitzer 4MTE-10K	40	0,90	8,99	8,61	1,04	1,12	11,17	9,18	1,22	1,35	13,55	9,59	1,41	1,61	16,07	9,82	1,64	1,86	18,64	9,89	1,88
	38	0,95	9,50	8,50	1,12	1,17	11,73	8,98	1,31	1,41	14,13	9,30	1,52	1,66	16,61	9,45	1,76	1,91	19,06	9,45	2,02
	32	1,10	11,02	7,94	1,39	1,31	13,13	8,18	1,61	1,51	15,08	8,26	1,82	1,68	16,83	8,20	2,05	1,84	18,44	8,02	2,30
	25	1,34	13,37	7,84	1,70	1,64	16,43	8,04	2,04	1,98	19,77	8,10	2,44	2,32	23,16	8,01	2,89	2,62	26,21	7,80	3,36
	15	1,54	15,43	6,37	2,42	1,84	18,37	6,44	2,85	2,16	21,58	6,44	3,35	2,51	25,09	6,37	3,94	2,89	28,88	6,23	4,64
	5	1,85	18,45	5,37	3,44	2,17	21,66	5,23	4,14	2,56	25,61	5,31	4,82	2,97	29,70	5,20	5,71	3,41	34,12	5,04	6,77
	N. of fans 2x500																				
	Weight 570 kg																				
	Sound pressure 44 dB(A)*																				
	Minimum Energy Performance Standards 2,68 (according Ecodesign Directive EN 2009/125/EC)																				
Annual Energy Consumption 30081 kWh/year																					
MRA/Pmax 26,3 A / 13,8 kW																					
UMT 150 VS MTDX Bitzer 4KTE-12K	40	1,36	13,63	12,67	1,08	1,69	16,89	13,17	1,28	2,04	20,40	13,60	1,50	2,89	28,88	13,94	2,07	3,33	33,29	14,14	2,35
	38	1,43	14,35	12,31	1,17	1,77	17,69	12,77	1,39	2,12	21,22	13,16	1,61	2,98	29,78	13,43	2,22	3,40	33,98	13,55	2,51
	32	1,63	16,33	11,21	1,46	1,94	19,43	11,52	1,69	2,22	22,25	11,72	1,90	2,97	29,72	11,76	2,53	3,25	32,51	11,63	2,80
	25	1,99	19,93	11,05	1,80	2,46	24,56	11,33	2,17	2,95	29,51	11,49	2,57	4,13	41,33	11,50	3,59	4,66	46,58	11,32	4,11
	15	2,31	23,05	9,00	2,56	2,74	27,35	9,18	2,98	3,21	32,09	9,25	3,47	4,48	44,76	9,21	4,86	5,16	51,58	9,04	5,71
	5	2,82	28,22	7,66	3,69	3,30	33,01	7,68	4,30	3,83	38,33	7,61	5,04	5,31	53,09	7,41	7,16	6,09	60,87	7,11	8,56
	N. of fans 2x500																				
	Weight 645 kg																				
	Sound pressure 45 dB(A)*																				
	Minimum Energy Performance Standards 2,80 (according Ecodesign Directive EN 2009/125/EC)																				
Annual Energy Consumption 42608 kWh/year																					
MRA/Pmax 33,4 A / 18,6 kW																					
UMT 190 MTDX Bitzer 4HTE-20K	40	1,77	17,72	15,55	1,14	2,13	21,33	16,33	1,31	2,52	25,16	16,92	1,49	2,90	29,00	17,31	1,67	3,27	32,67	17,53	1,86
	38	1,85	18,54	15,17	1,22	2,21	22,11	15,84	1,40	2,58	25,80	16,33	1,58	2,94	29,41	16,62	1,77	3,28	32,80	16,75	1,96
	32	2,19	21,88	14,41	1,52	2,29	22,88	14,17	1,61	2,88	28,79	14,93	1,93	3,36	33,56	15,33	2,19	3,85	38,51	15,64	2,46
	25	2,59	25,90	13,60	1,90	3,08	30,78	13,91	2,21	3,56	35,63	14,05	2,54	3,99	39,87	14,02	2,84	4,33	43,29	13,85	3,13
	15	2,85	28,47	11,25	2,53	3,34	33,36	11,46	2,91	3,88	38,82	11,59	3,35	4,48	44,78	11,67	3,84	5,12	51,17	11,68	4,38
	5	3,37	33,70	9,65	3,49	3,94	39,44	9,71	4,06	4,58	45,81	9,74	4,70	5,27	52,72	9,76	5,40	6,01	60,08	9,74	6,17
	N. of fans 3x500																				
	Weight 655 kg																				
	Sound pressure 45 dB(A)*																				
	Minimum Energy Performance Standards 2,71 (according Ecodesign Directive EN 2009/125/EC)																				
Annual Energy Consumption 51896 kWh/year																					
MRA/Pmax 42,4 A / 24 kW																					

NOTE: Inverter modulation from 30 to 60 Hz except / cooling capacity min @30Hz - @60Hz except** @50Hz
 Varistep modulation from 10 to 100 % of the capacity @ 50 Hz
 (*based on free field area weed semi-spherical sound emission in 10m distance; tolerance ± 2 dB(A))

		Evaporation Temperature[°C]												
		-40			-35			-30			-25			
		Cooling Capacity [kW]		COP	Cooling Capacity [kW]		COP	Cooling Capacity [kW]		COP	Cooling Capacity [kW]		COP	
min	max	min	max		min	max		min	max					
T amb [°C]														
	UMT 030 BTDX	Dorin CD2S 300	40	-	-	-	-	-	1,38	2,11	0,97	1,58	2,38	1,05
38			-	-	-	1,22	1,84	0,94	1,42	2,14	1,02	1,64	2,46	1,11
32			1,08	1,62	0,94	1,26	1,90	1,04	1,53	2,29	1,12	1,73	2,59	1,31
20			1,17	1,75	1,25	1,37	2,05	1,39	1,66	2,48	1,60	1,90	2,86	1,77
N. of fans 2x500														
Weight 460 kg														
Sound pressure 48 dB(A)*														
Minimum Energy Performance Standards 0,96 (according Ecodesign Directive EN 2009/125/EC)														
MRA/Pmax 10,4 A / 4,2 kW														
UMT 035 BTDX			Dorin CD2S 350	40	-	-	-	-	-	1,62	2,42	0,99	1,88	2,82
	38	-		-	-	1,46	2,18	0,97	1,67	2,51	1,05	1,94	2,92	1,15
	32	1,30		1,96	1,03	1,54	2,30	1,14	1,78	2,68	1,12	2,06	3,10	1,36
	20	1,44		2,16	1,35	1,69	2,53	1,49	1,98	2,98	1,66	2,31	3,47	1,84
	N. of fans 2x500													
	Weight 465 kg													
	Sound pressure 48 dB(A)*													
	Minimum Energy Performance Standards 1,01 (according Ecodesign Directive EN 2009/125/EC)													
	MRA/Pmax 11,7 A / 4,7 kW													
	UMT 036 BTDX	Dorin CD2S 360		40	-	-	-	-	-	2,09	3,13	0,99	2,44	3,66
38			-	-	-	1,86	2,80	0,97	2,16	3,24	1,05	2,50	3,76	1,14
32			1,67	2,51	1,03	1,97	2,95	1,13	2,29	3,43	1,23	2,68	4,02	1,36
20			1,86	2,78	1,34	2,19	3,29	1,50	2,55	3,83	1,64	2,97	4,45	1,81
N. of fans 2x500														
Weight 470 kg														
Sound pressure 48 dB(A)*														
Minimum Energy Performance Standards 1,60 (according Ecodesign Directive EN 2009/125/EC)														
MRA/Pmax 11,7 A / 4,7 kW														
UMT 120 BTDX			Dorin CD2S 1200	40	-	-	-	-	-	8,05	12,07	1,01	9,24	13,86
	38	-		-	-	7,07	10,61	0,98	8,28	12,42	1,07	9,51	14,27	1,15
	32	6,16		9,24	1,01	7,35	11,03	1,13	8,58	12,86	1,23	9,96	14,94	1,34
	20	6,56		9,84	1,29	7,78	11,68	1,45	9,14	13,72	1,59	10,57	15,85	1,73
	N. of fans 3x500													
	Weight 560 kg													
	Sound pressure 50 dB(A)*													
	Minimum Energy Performance Standards 1,70 (according Ecodesign Directive EN 2009/125/EC)													
	MRA/Pmax 32,4 A / 13,2 kW													

NOTE: Inverter modulation from 40 to 60 Hz / cooling capacity min @ 40 Hz - max @ 60 Hz
 (*based on free field area weed semi-spherical sound emission in 10m distance; tolerance ± 2 dB(A))

Dimensional Data

MTDX - 2 fans

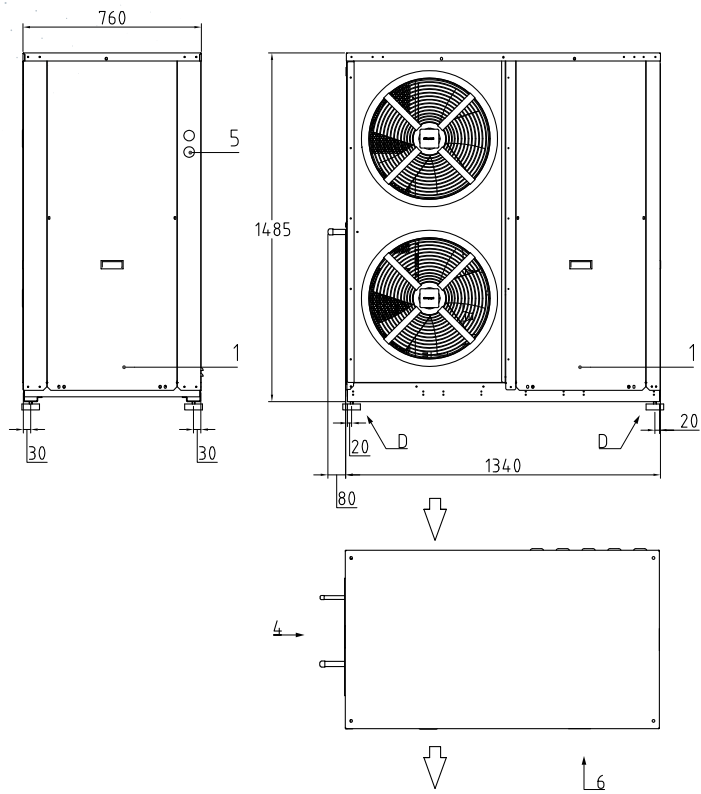

MTDX - 3 fans

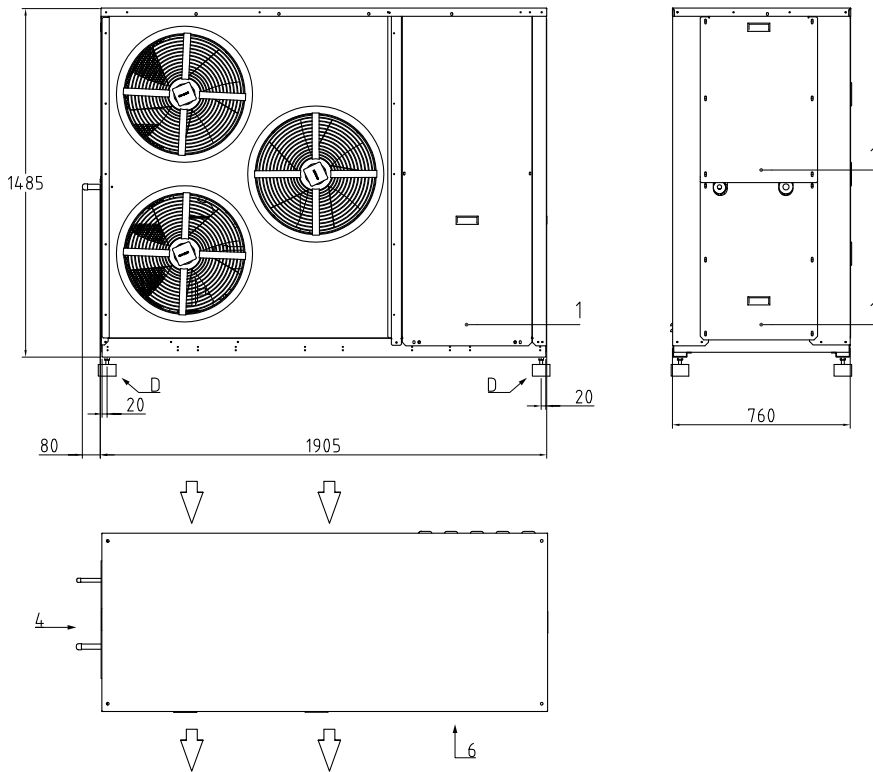

Dimensional Data

BTDX - 2 fans

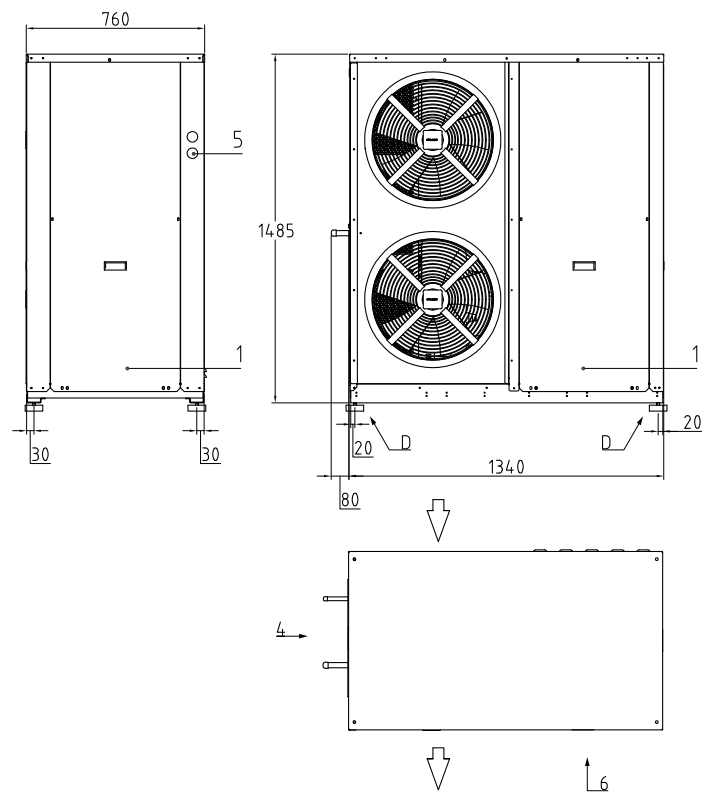

Unit Configuration

MODEL UMT T MTDX

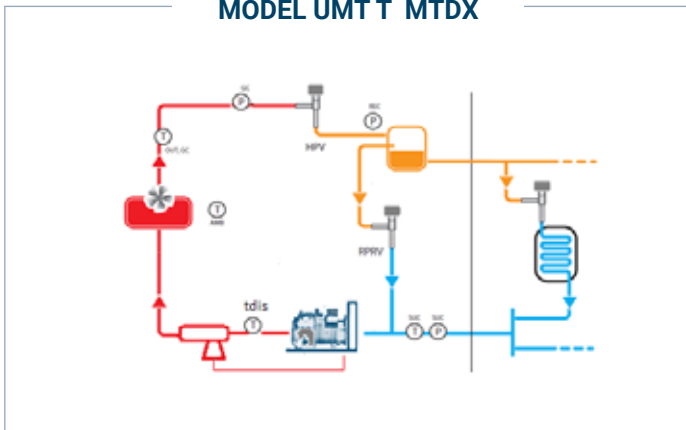

Management of one BLDC compressor
Communication with cabinets (MPXPRO or ULTRACELLA)

MODEL UMT T BTDX

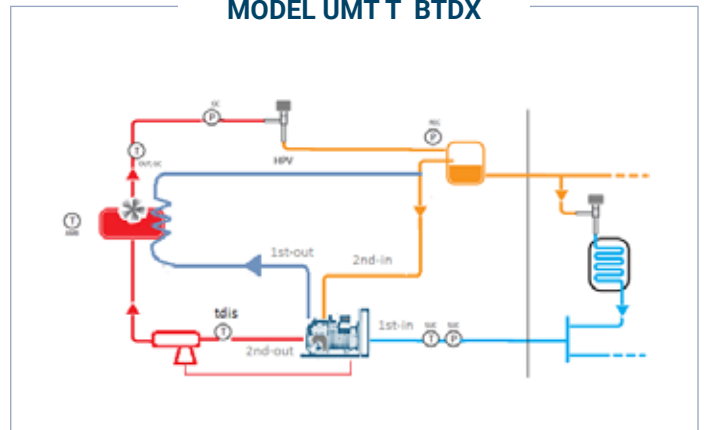

Management of two BLDC compressor (LT and parallel compressors)
Communication with cabinets (MPXPRO or ULTRACELLA)
Floating receiver pressure (-10°C / 0°C)

Installation Design

Multi-Split

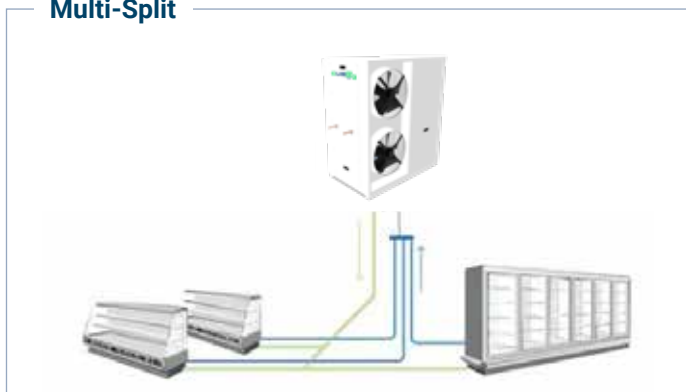

Branch



Pipe Connections (Multi-Split or Branch)

The connection between the Condensing Unit and more remote evaporators can be the same one used for Multi-Split or branch system.

The preferred one is the one is able to guarantee the highest gas velocity in the suction line (for a good oil return) with a low pressure drop.

For Multi-Split layout, the system requires a dedicated suction line for each evaporator that will be collected by a manifold installed close to the condensing unit.

Please refer to the example reported in the pictures.

- Liquid line must be properly sized to supply the farther evaporators (liquid velocity < 1 m/s is suggested).
- Suction line must be properly sized to have a good oil return with a low pressure drop (gas velocity min 5m/s).

CO₂ INDUSTRIAL NATURAL REFRIGERATION CHOICE



Non-flammable

which means the electrical panel can be in same room as the plant, saving on plant saving on plantroom and installation costs.

Non-toxic

has no charge limitation/concerns and can be used across a wide platform.

CO₂ packs will have multiple compressors

providing built-in resilience in case a compressor fails.

Non-flammable

which means there is no requirement for ATEX fans and other explosion-proof equipment.

Does not require regular compressor overhauls

saving on maintenance costs.

Is now standard refrigerant in commercial installations

making it easily transferable to industrial settings. There is a larger pool of companies and engineers available to provide installation and service

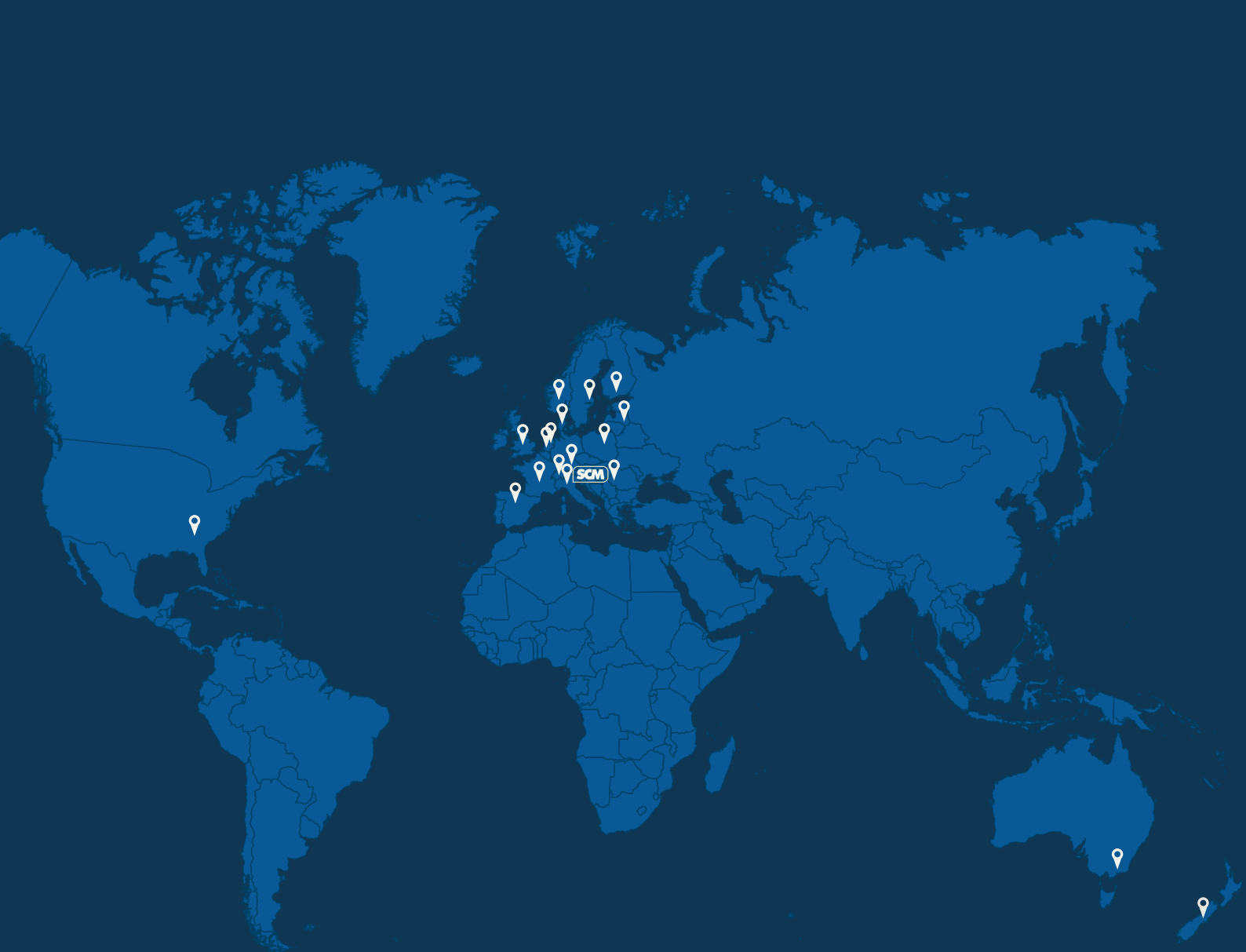

Stay connected.

Follow our LinkedIn page to discover more stories from our team and insights into what makes SCM Frigo a leader in innovation and sustainability.



Connect with Us
on LinkedIn

 www.scmfrigo.com  +39 049 970 5000  info@scmfrigo.com



A **BEIJER REF** Company

SCM FRIGO S.p.A. - Viale Andrea Palladio, 31 35020 Sant'Angelo di Piove di Sacco

